

ray

protherm



**User and installation instructions for direct heating
electric boiler**

RAY 9 - 24K

Operation and installation instructions

1. Introduction.....	2
1.1. Quality assurance equipment and personal safety.....	2
2. Boiler characteristics and equipment.....	3
2.1. Characteristics.....	3
2.2. Boiler equipment.....	3
3. Control and signalling.....	4
4. Conditions for installation and operation.....	5
5. Boiler connection dimensions and pump characteristics.....	6
6. Mounting and placement of the boiler.....	7
6.1. Wiring.....	7
6.2. Cascade control.....	8
7. Operations.....	8
8. Maintenance.....	9
9. Complete parts supply.....	9
10. Warranty and warranty conditions.....	9
11. Transport and storage.....	9
12. Technical parameters.....	10
13. Boiler wiring diagram.....	11
13.1. Wiring diagram of two boilers connected to cascade.....	12
14. Interconnection the electric boiler with a DHW tank.....	12

DEAR CUSTOMER

You have just become the owner of a direct heating electric boiler which was designed for central heating systems with a user friendly regulation option for thermal comfort.

PROTHERM wants your electric boiler to serve you at a high level of efficiency. In order for it to do so, it is necessary to adhere to certain principles when installing and operating the boiler. Therefore we would ask you to carefully read the operating instructions and put them into use during operation.

We believe that our PROTHERM electric boiler will bring about optimal thermal comfort and result in a truly pleasant environment.

We would ask you to pay close attention to the following important points:

1. The boiler and all related equipment must be installed and made use of in accordance with the design, all relevant valid regulations and technical standards and according to the manufacturer's directions.
2. The boiler can only be installed in an environment it has been designed for.
3. The installation and initiation (or later restarting) of operation can be only undertaken by a professional individual, authorised by the manufacturer.
4. Please, refer to a professional authorized by the manufacturer in case of failure – unprofessional intervention can lead to damage to the boiler (or – eventually – to the related equipment)!!
5. Check if all parts have been supplied.
6. Check, if the supplied boiler type corresponds with the type required for use.
7. When uncertain about boiler operation, please, do not neglect to look up and study all relevant information located in the operating instructions and carry out everything in accordance with them.
8. Do not remove or damage any labels or written notices on the boiler.
9. The boiler complies with the following standards: CSN EN 60335 – 1: 1997 CSN EN 50081 – 1:1994, CSN EN 55014-1:1995, CSN EN 61000-3-2+A12:1997, CSN EN 61000-3-3:1997 CSN EN 55 014-2:1998, CSN EN 06 1008:1997.
10. At the end of its service life the boiler and its parts should be treated with respect to the environment.

1. INTRODUCTION

In accordance with development trends in the area of electric boilers, PROTHERM company has introduced electric direct heating boilers of the REJNOK series, produced in 9, 12, 15, 18, 21 and 24 kW versions.

This boiler has a high utility value, i.e. it is well equipped, which makes it independent of the heating system equipment. Through the use of a simple control panel it is possible to adjust the boiler operation according to the conditions of the given building.

1.1. QUALITY ASSURANCE OF EQUIPMENT AND PERSONAL SAFETY

In addition to the requirements of the above mentioned documents, it is necessary to adhere to these instructions and the accompanying manufacturer's documentation of the boiler while using this boiler. Also essential is intervention by children, intoxicated persons, irresponsible persons, etc.

The manufacturer's products conform to the standards of the examined type through maintaining technological discipline through its quality control system in accordance with the ISO 9001 standard.

A constant high level of care for the product and the user (i.e. on installation, placing into operation, acquaintance with usage, setting and regulation in accordance with local conditions, during the warranty and after warranty period) is provided by a network of contract partner companies with qualifications in correspondence.

2. BOILER CHARACTERISTIC AND EQUIPMENT

2.1. CHARACTERISTICS

PROTHERM electric boilers are designed for usage in heating warm-water systems with forced water circulation. They serve as heaters of heating water, which is then pumped and distributed through central and level heating systems to heating bodies.

The electric boiler has a function of sequential on/off switching of power at intervals of maximum 6 kW with 10-70 seconds delay according to the boiler output, so that undesirable impulses in the mains are eliminated on the electric boiler switch-off and switch-on. The circulation pump only works when it is necessary, thereby saving energy and reducing mechanical wear. The pump stays in operation for 2 minutes after the electric boiler switch-off, so that warm water remaining in the boiler body and distribution system after switch-off can be utilized.

The electric boiler is mounted into a steel case with a front panel integrated with side panels attached to the back panel with screws. The heating water inlet and outlet are at the bottom of the boiler as well as an electrical connection.

The REJNOK series boilers are designed for mounting on a wall.

In order to achieve higher output, the electric boilers can be cascade-connected, and controlled by only one temperature controller connected to the primary electric boiler.

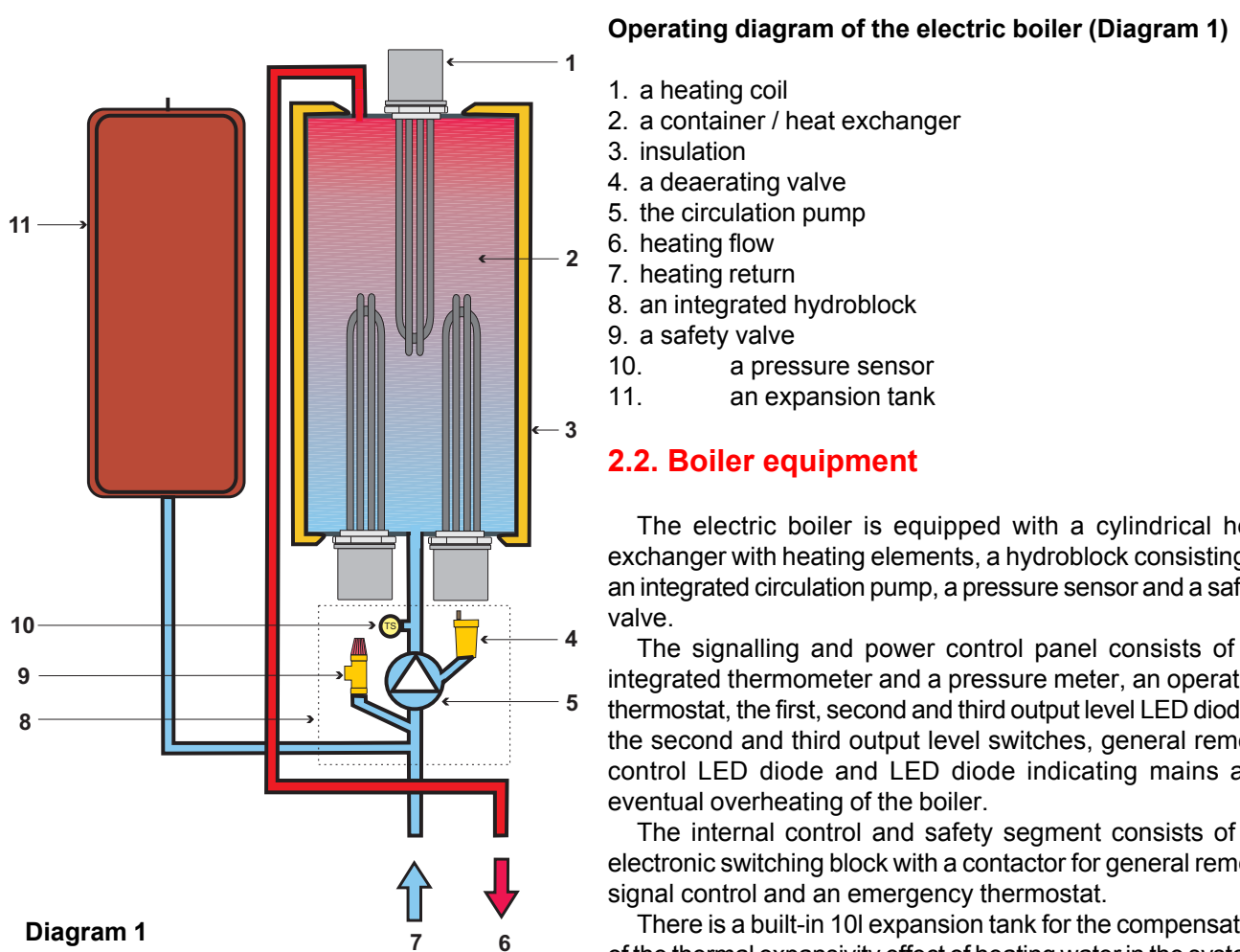

3. Control and signalling

The electric boiler is designed for unmanned operation. After switching on of the main power supply switch there is a green signal light lit on the control panel (see the picture of the control panel) signalling, that the electric boiler is connected to the mains. The white general remote control LED diode signalizes, that the contactor controlled by the general remote control is switched on and also signalizes if there is an interruption of the lower tariff of the direct heating rate. the LED diode is on when the lower tariff is active.

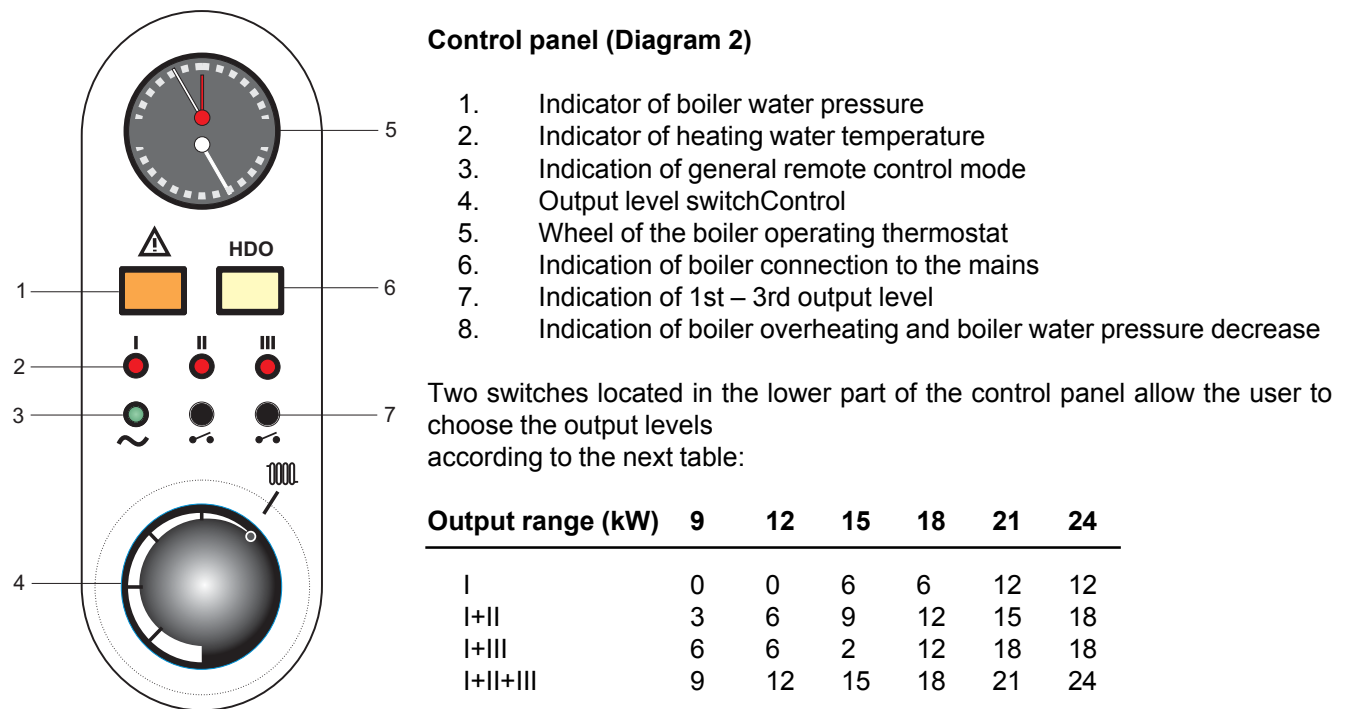

Diagram 2

Lit LED diodes II and III above switches signalize that switches are turned on and that the appropriate heating elements inside the electric boiler are heating. LED diode I signalizes that the first output level is switched on and also signalizes the moment when the boiler is switched on/off by the indoor temperature controller or by a boiler thermostat, when the ripple control is switched on. If there are two or more electric boilers working in a cascade connection, the second electric boiler always turns on with a delay after switch-on of the bottom switch of the preceding boiler. Along with the boiler thermostat, the maximum heating water temperature can be set, heated in the electric boiler. The boiler thermostat has to be set in accordance with the mounting company instructions, because the maximum heating water temperature depends on the type of heating system (floor heating, fitting of thermostatic heads, heating of hot water). Please set the indoor temperature controller according to the user instructions. When using classical central heating with heating bodies and with an indoor temperature controller it is necessary to set the boiler thermostat to a higher temperature - e.g. to 80 °C. Do not however be surprised that the water in the heating system will not reach that temperature. The indoor temperature controller will stabilize the water temperature on a level necessary for reaching the required indoor air temperature. By setting the boiler thermostat to a higher temperature, prevention of the switch-off of the electric boiler is achieved when the set temperature of the water is too low so as to not influence indoor temperature room regulation. The boiler operating thermostat has a limiting function when control is executed in this way.

Output preset value depends on heat loss in your flat or house, on external temperature, on required indoor temperature, or if you use your electric boiler also for the heating of hot water. Full output operation at temperatures around or above 0°C will not cause damage to the electric boiler.

When heating two flats it is necessary to set output so as to be sufficient for covering losses for both flats.

The electric boiler is equipped with a safety thermal cut-out – safety thermostat and pressure sensor for securing of safe operation. The safety thermostat will shut down the boiler irreversibly when the water exceeds the critical temperature (100 °C). This will be signalized by a yellow signal light. When a reaction of this kind does not occur, call a service engineer immediately in order to detect the true cause, repair the boiler and put it into operation again.

Annotation: no any time its must be a warranty revision.

Never try to repair the boiler yourself! This situation is rare and will not be encountered on a regular basis. The pressure sensor prevents the boiler switch-on if there is a leakage of water from the heating system and if the water pressure drops below 0,8 Bar, so that the heating elements are protected from damage in case of operation without

water in the system. A pressure drop is also signaled by a yellow signal light. The type of failure can be identified according to the integrated pressure meter/thermometer reading.

In order to achieve maximum operation efficiency (minimalized electricity costs) it is necessary to add an appropriate regulating mechanism to your heating system, which maintains the required temperature when you are at home and will lower the indoor temperature automatically at night or when nobody is at home.

4. Conditions for installation and operation

The connection for electric heating is subject to approval by a local distribution company. An applicant has to seek preliminary approval with an option for connection to a higher electric input and has to apply for a direct heating rate for flats.

When installing new central heating or reconstructing an old one, we recommend professional carrying out of the project so as to ensure an economical and failure-free system.

The electric boiler can be connected to the heating system only by a competent heating engineer. The connection to the mains and the electric wiring can only be done by a professional qualified in accordance .

The electric boilers are designed for permanent connection to fixed mains. A switch has to be integrated into the boiler fixed mains as a main switch and the gap of its disconnected contacts has to be bigger than 3 mm at all poles.

It is necessary to choose a suitable place for the electric boiler, counting on a certain amount of space in front of the boiler, necessary for handling as well as under the boiler for connection of inlet and outlet heating system piping. Minimum distances between the electric boiler and a proof check are demonstrated on a Diagram 3.

Provision of warranty is conditioned by professional installation carried out by an authorized service company! Therefore please contact our contract partners who will help you in acquiring necessary technical data, will connect your boiler professionally and will also advise you in questions of operation of your electric heating.

After installation you should ask a competent employee of the company which carried out the installation to demonstrate how the system functions and train you in working with the boiler. A competent worker has to certify the electric boiler warranty certificate after putting the boiler into operation.

The electric equipment of the boiler is designed for handling with no need for electrotechnical qualification. The handler is allowed to manipulate only with those control elements specified in these usage instructions, eventually specified by a service company. The handler is not allowed to change the wiring.

It is necessary that there is pressure water for filling of the system and also the possibility for drainage of the system in the place where the electric boiler will be installed. It is also necessary that there is a straight wall in the room (the electric boiler is mounted on the wall).

The electric boiler is designed for operation in a standard environment (i.e. temperatures from +5 to +40 °C, humidity up to 85% depending on temperature).

The boiler must not be installed in bathrooms, wash-rooms and shower-rooms . It should also not be installed if there is the possibility that the water stream will reach the boiler (e.g. in public baths, bath-rooms and showers, located in schools, factories, sport clubs, other public facilities, etc.).

When the boiler is installed in permitted zones, there must be protection against electric shock in accordance with the same standard.

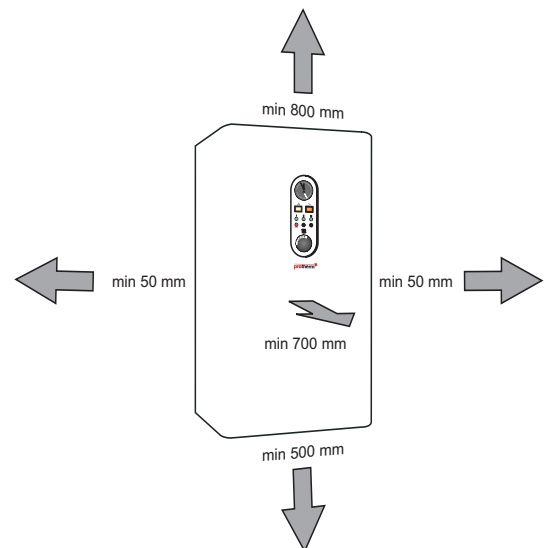
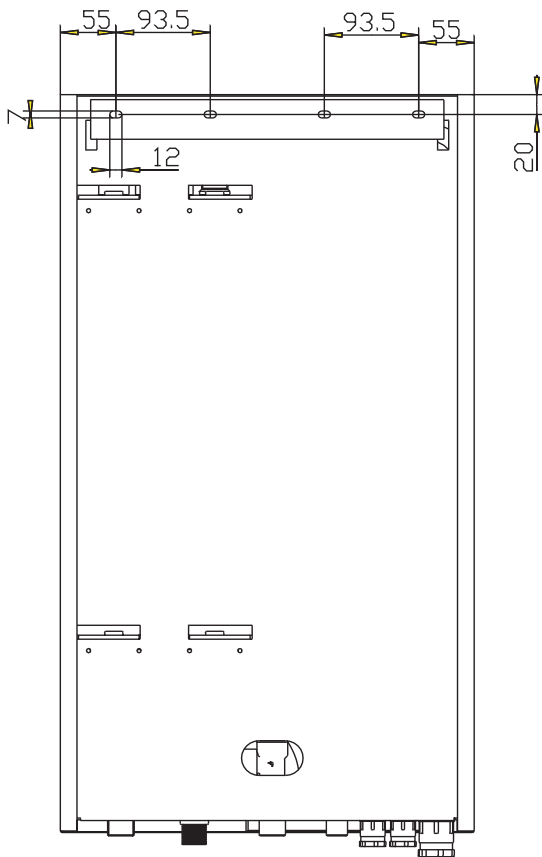
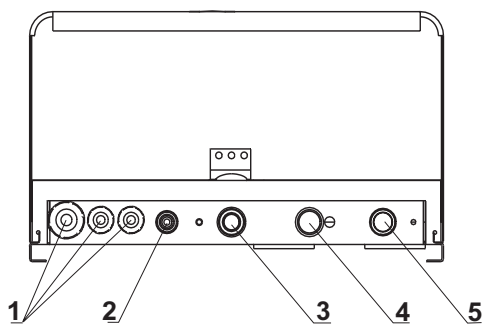
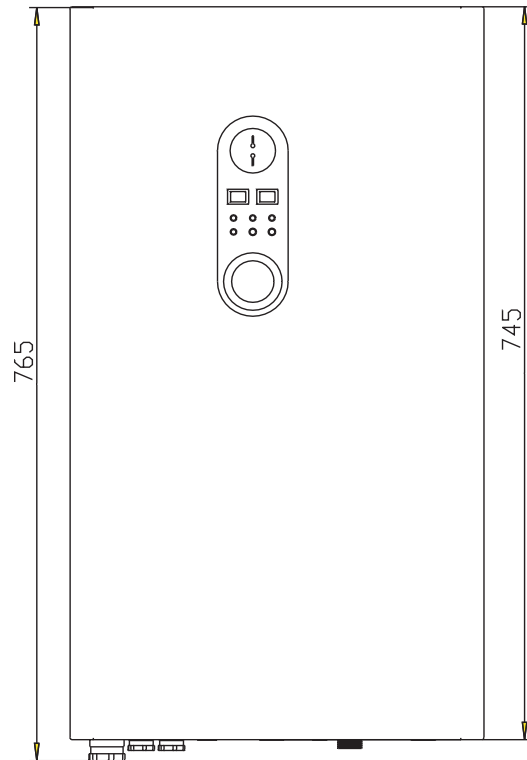

Diagram 3

5. Boiler connection dimensions and pump characteristics



rear view



bottom view

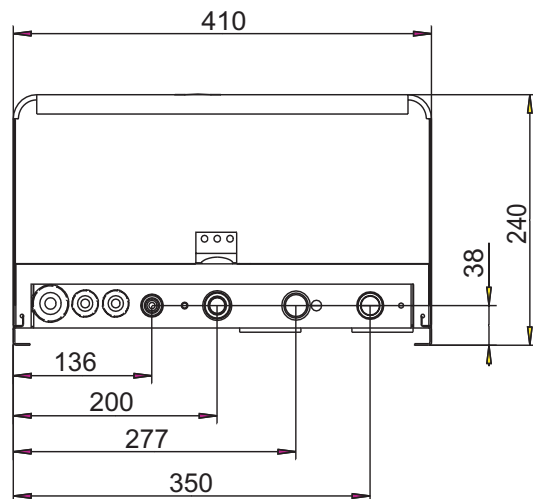

Boiler connection description

1. a cable bushings
2. filling / draining 1/2"
3. a heating water inlet 3/4"
4. overflow of a safety valve
5. a heating water outlet 3/4"

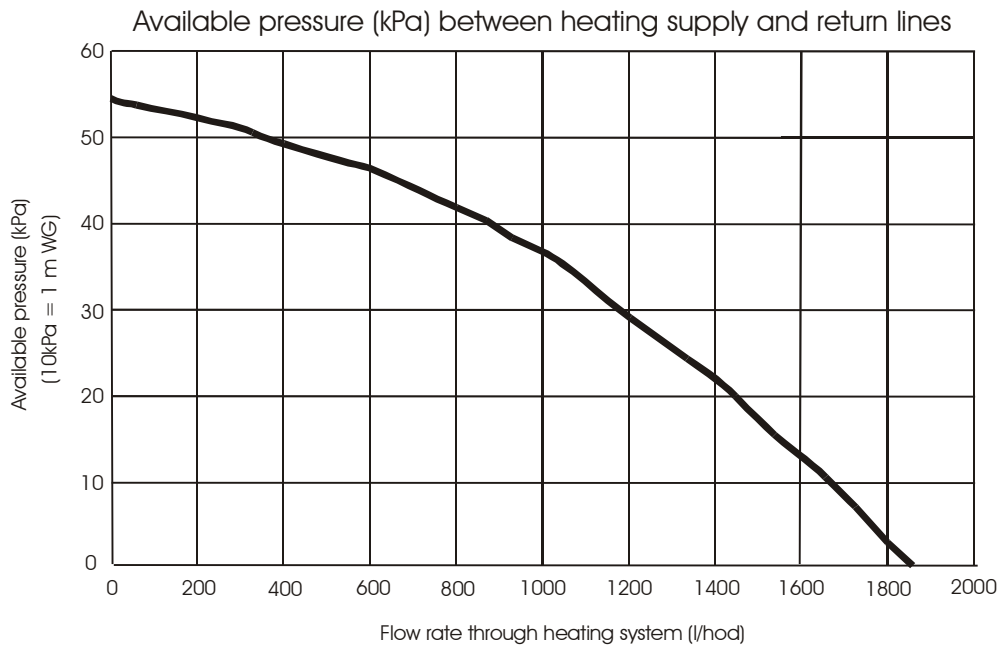

6. Mounting and placement of the boiler

The mounting rail (is included) is recommended for mounting the boiler on the wall see Diagram 6. First fix the rail on the wall. On this rail hang the heater unit with the pump and accessories. The boiler casing is removable and is fixed to the rear panel with screws. It is necessary before mounting to find a place where the boiler can be serviced without any obstructions.

If the boiler is installed to an open system the heating water column must produce a pressure of min. 1bar.

In heating systems fitted with thermostatic heads, water circulation can be completely closed, and it is necessary to mount a by-pass leading through one heating body, which is not fitted with thermostatic heads or to use another by-pass.

The use of non-freezing mixtures is not recommended due to their properties which are not suitable for boiler operation – particularly reduction of heat transfer, high expansivity, aging, damage to rubber parts. If there is no other possibility of reliable prevention of freezing of the heating system, then non-fulfilment of some functional parameters or eventual boiler failure caused by usage of non-freezing mixtures can not be included as a area of warranty.

Prior to the final mounting of the boiler it is necessary to flush the boiler distribution system several times with pressure water. Older, already used systems should be flushed in the direction which is opposite to the direction of the heating water. In new systems all heating bodies should be flushed with pressure water to remove preserving agents.

Placement of a sediment catcher before the boiler is recommended (i.e. to the return heating water piping). The sediment catcher should allow regular draining without having to drain a lot of heating water. The sediment catcher can be combined with a filter. A filter itself with a sieve, however, is not sufficient for protection.

The warranty does not apply to clogging of the boiler by heating system contaminants and to failures caused by such a clogging.

Note: The filter and the sediment catcher must be checked and cleaned regularly.

Before a filling the heating system of water is a requirement to check a pressure in an expansion tank. An additional completion of the pressure from among 1-1,3 bar is made if necessary.

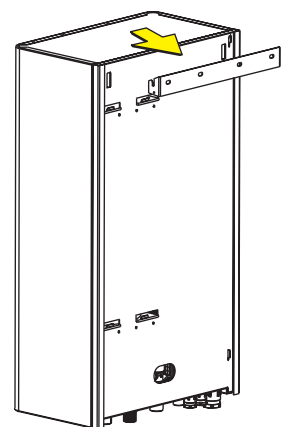

Diagram 6

6.1. Wiring

The user has to arrange a power electric connection with a main switch for heating, protection, and other adjustments of the house wiring including its initial revision and application for electricity supply.

Bushings for mains connection, connection of a spatial controller, a general remote control, or a cascade connection

are located in the lower left corner of the bearing frame (frontal view). We also mount an external protective terminal (brass M6 screw).

The paint has to be removed from the surface around the screw inside the case and on its outer side before fitting of the protective terminal. We connect a protective conductor ended with a cable lug under the head of the screw inside the case. On the outer side we tighten a brass nut with a fan-shaped washer. The second nut is used for connection of the external protective conductor.

Simple and also more complicated regulation elements such as programmable indoor temperature controllers (daily or weekly programme) are available at the PROTHERM electrical boilers company and through its contract partners. For proper operation of PROTHERM electric boilers it is necessary to install controllers with zero output voltage. The required current carrying capacity of output contacts of the controller is 230 V / 0,1 A. Indoor temperature controllers with zero potential output are connected to RT terminals.

6.2. Cascade control

If the output of the boiler does not cover the heat loss of the building, there is a possibility to connect another heat source to boilers of the 21 and 24 series. To enable so-called cascade control connect K 1 and K 2 terminals of the controlling boiler with the PR 1 and PR 2 terminals of the controlled boiler. If there is a need for cascade control, ensured by the spatial thermostat, we connect its control terminals with the PR 1 and PR 2 terminals of the controlling boiler.

7. Operations

After connection of the electric boiler to the heating system (according to local conditions) the system is filled with soft water and the tightness of the entire system is checked simultaneously. Additional sealing is made if necessary.

After completing installation, the operating thermostat function is checked along with the thermal cut-off, pressure switch and control elements on the panel.

Note: Before the initial start-up of the boiler it is necessary to set the boiler operating thermostat to the minimum level, due to undesirable air intake. After the switch-on of the main switch of the boiler (the green signal light is lit) and after checking the active function of the general remote control turn the operating thermostat of the boiler until the LED diode of the first output level is lit. Subsequently, turn the operating thermostat back to the minimum level. This will activate the after-running function of the pump with a duration of 2 minutes. It is recommended to repeat this two times.

If the orange signal light is on, then the boiler has probably overheated or there was a water pressure drop in the boiler. In the first case a professional service engineer should check the emergency thermostat above the control panel, see pic. 7. The emergency thermostat is irreversible, so the failure has to be deblocked by a deblocking button (a). In the second case there was a water pressure drop in the boiler. This can be only solved by filling the system with water, until the water pressure rises above 1 bar. The orange signal light is then switched off.

Before an any check into an inside part of the electric boiler relevant to parts which are in a contact with a water or a wiring it's necessary to fill following conditions:

- to switch off the boiler by means of the room thermostat or the operating thermostat
- to wait for c. 2 minutes
- to disconnect the boiler from off the permanent input connection of mains (a circuit breaker)
- to close valves under the boiler (inlet, outlet)
- to drain a water from the boiler (drain cock)

After a finish of the control or a possible revision check before the repeated switching of the electric boiler to the mains, if the water doesn't issue out of the boiler.

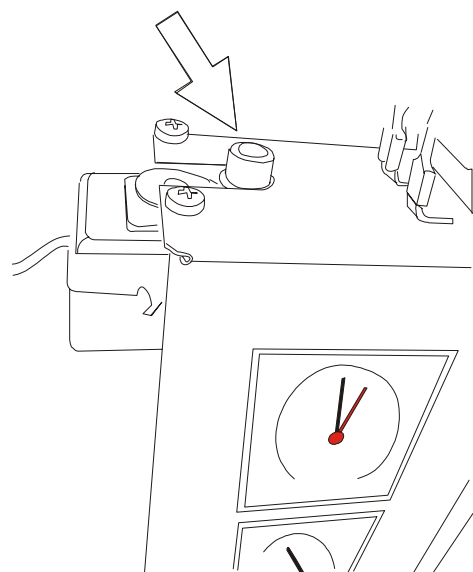

Diagram 7

8. Maintenance

The electric boiler does not require maintenance. It is recommended, however, that a service company check the boiler once a year, preferably before the heating period (this is not included in the warranty). The skilled control should to tighten all the electric and water connections, to clear a pump, a safety and a deaerating valve, to check safety components and in ending globally to attest a correct function of the boiler.

The water pressure has to be checked regularly, when using the boiler in a closed heating system with an expansion pressure tank. If the overpressure in a cold system drops under the level marked by the installation company, it is necessary to carry out a professional revision of the system. It's invalid at a first heating and by subsequently operating time, when e.g. an air is evolved from a system. There it's necessary the system to fill with water in accordance with a standard. When using an open heating system, it is necessary to check the water level in the expansion tank and refill the lost water.

9. Complete supply of parts

The electric boiler is supplied in an assembled state. The connecting wires for the electric boiler and connecting wires for the indoor temperature controller are not included in the supply of parts.

The complete supply consists of these components and documentation:

- the electric boiler in an assembled state
- mounting rail (screws +dowels)
- external protective terminal
- a cable bushings
- user and installation instructions for the PROTHERM electric boiler
- warranty certificate
- quality certificate and complete supply of parts
- list of contract partners

10. Warranty and warranty conditions

The warranty is valid for the PROTHERM electric boiler in accordance to the certificate of warranty and the herein written conditions.

11. Transport and storage

The electric boiler is transported and stored in its original package – strong force application should be avoided, as well as shocks and the boiler should not be turned over to a position, in which it can slip out from the package.

Standard conditions have to be ensured for storage (a non-aggressive and dust-free environment, a temperature from 5 to 50 °C, air humidity up to 75 %, prevention of biological impacts, shocks and vibrations).

12. Technical parameters

Voltage.....	V.....	3 x 400 + N + PE, 50 Hz
Max. current (24kW).....	A.....	3 x 36 A
Power input *.....	kW.....	9, 12, 15, 18, 21, 24
Expansion tank.....	l.....	10l
Min. operating boiler overpressure.....	kPa.....	80
Max. operating boiler overpressure.....	kPa.....	300
Electric protection.....		IP 40
Heating water connection.....		G 3/4"
Filling/draining opening.....		G 1/2"
Dimensions:		
height.....	mm.....	745
width.....	mm.....	410
depth.....	mm.....	240
weight (without water).....	kg.....	34
Efficiency.....	%.....	99,5
Max. operating temperature of the heating water.....	°C.....	85
Max. delivery of the circulation pump.....	kPa.....	50
Recommended operating overpressure of the boiler.....	kPa.....	100 - 170

Recommended circuit breakers valves and cross-sectional area of power supply cable

type of Protherm boiler K (kW)	circuit breaker value (A)	Cross-sectional area of Cu power supply cable (mm ²)
9	16	1,5
12	25	2,5
15	25	2,5
18	35	4
21	35	4
24	50	6

13. Boiler wiring diagram

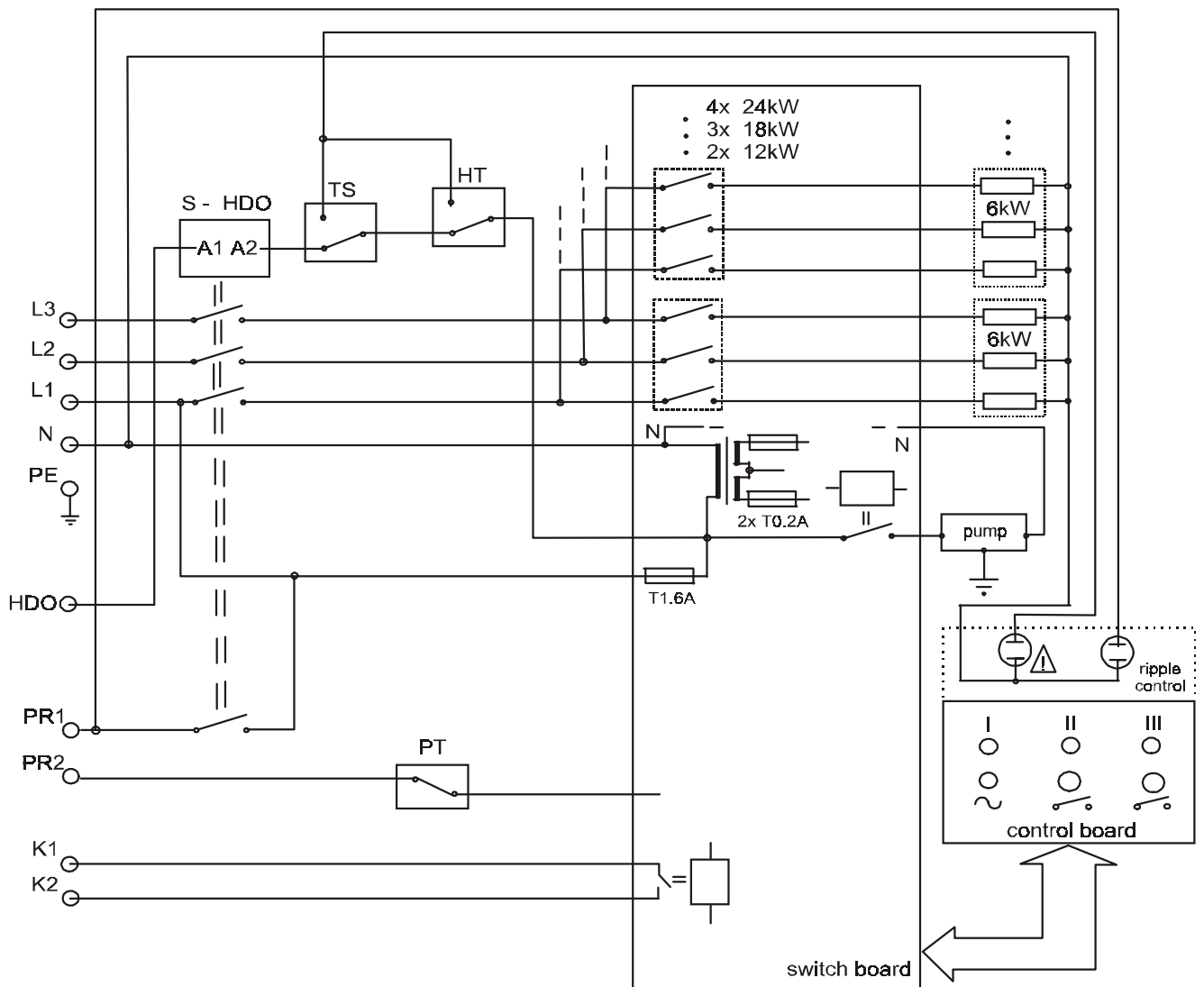

- TS – pressure switch 0,8 Bar
- HT – over heat thermostat 100°C
- PT – operating thermostat max. 85°C
- PR1,PR2 – room thermostat 230 V / 0,1 A
- HDO – ripple control
- S-HDO – RC contactor
- K1,K2 – cascade output (only 21 kW and 24 kW)

13.1. Wiring diagram of two boilers connected to cascade

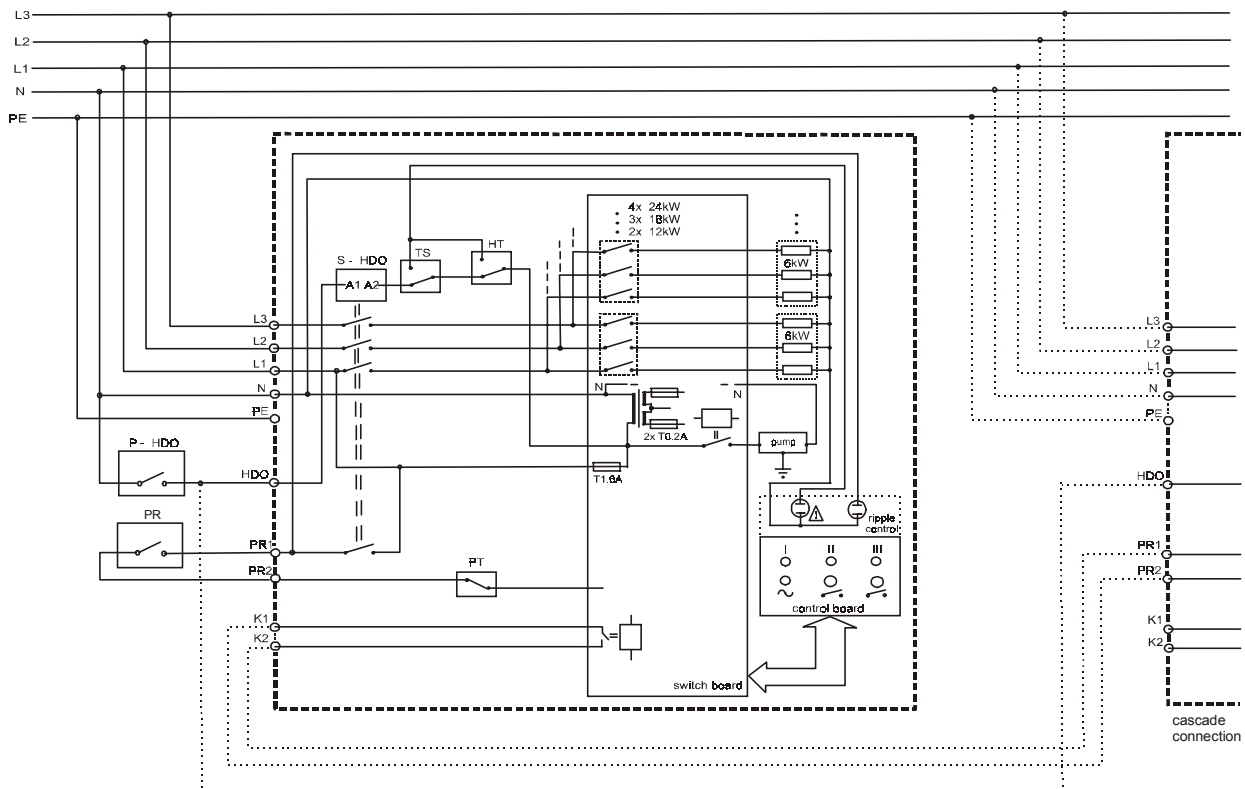

- TS – pressure switch 0,8 Bar
- HT – over heat thermostat 100°C
- PT – operating thermostat max. 85°C
- PR1,PR2 – room thermostat 230 V / 0,1 A
- HDO – ripple control
- S-HDO – RC contactor
- K1,K2 – cascade output (only 21 kW and 24 kW)

14. Interconnection the electric boiler with DHW tank

The electric boiler PROTHERM can be added to non-direct DHW tank PROTHERM of series B60Z, B100MS, B100Z, B200S and B200Z. For a correct communication between the boiler and the DHW tank it is necessary to fill the following conditions which relate to a picture on page No. 13.

Assembly conditions:

- to a distribution of heating water into a heating system or into DHW it is necessary to use a 3-way motor valve with donkey-switching contact (3/4" valve with an exterior screw - No. in an order 2046, 1" valve with an interior screw - No. in an order 2045)
- contacts of a room thermostat (PR) are played to donkey-contact W1 and W2 of the 3-way motor valve
- the room thermostat will be connected between a contact of a thermostat of the DHW tank TB2 and a contact of a supply phase of the 3-way valve motor

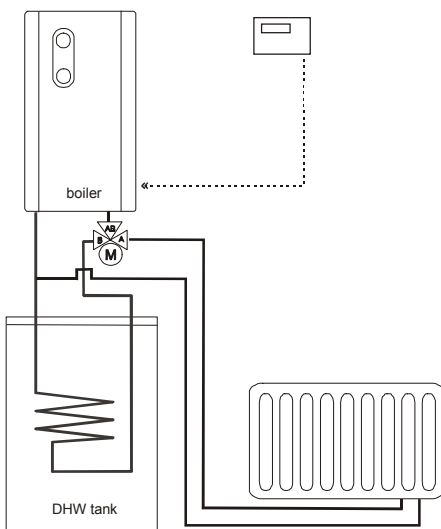

- to assurance a correct function of a preparation DHW its necessary fill the switching relay with following parameters: switching contact current above 0,5 A / switching voltage 0-230 V, control voltage 230 AC
- at the interconnection the electric boiler with the DHW tank its always necessary made it in accordance with conditions in user and installation instructions

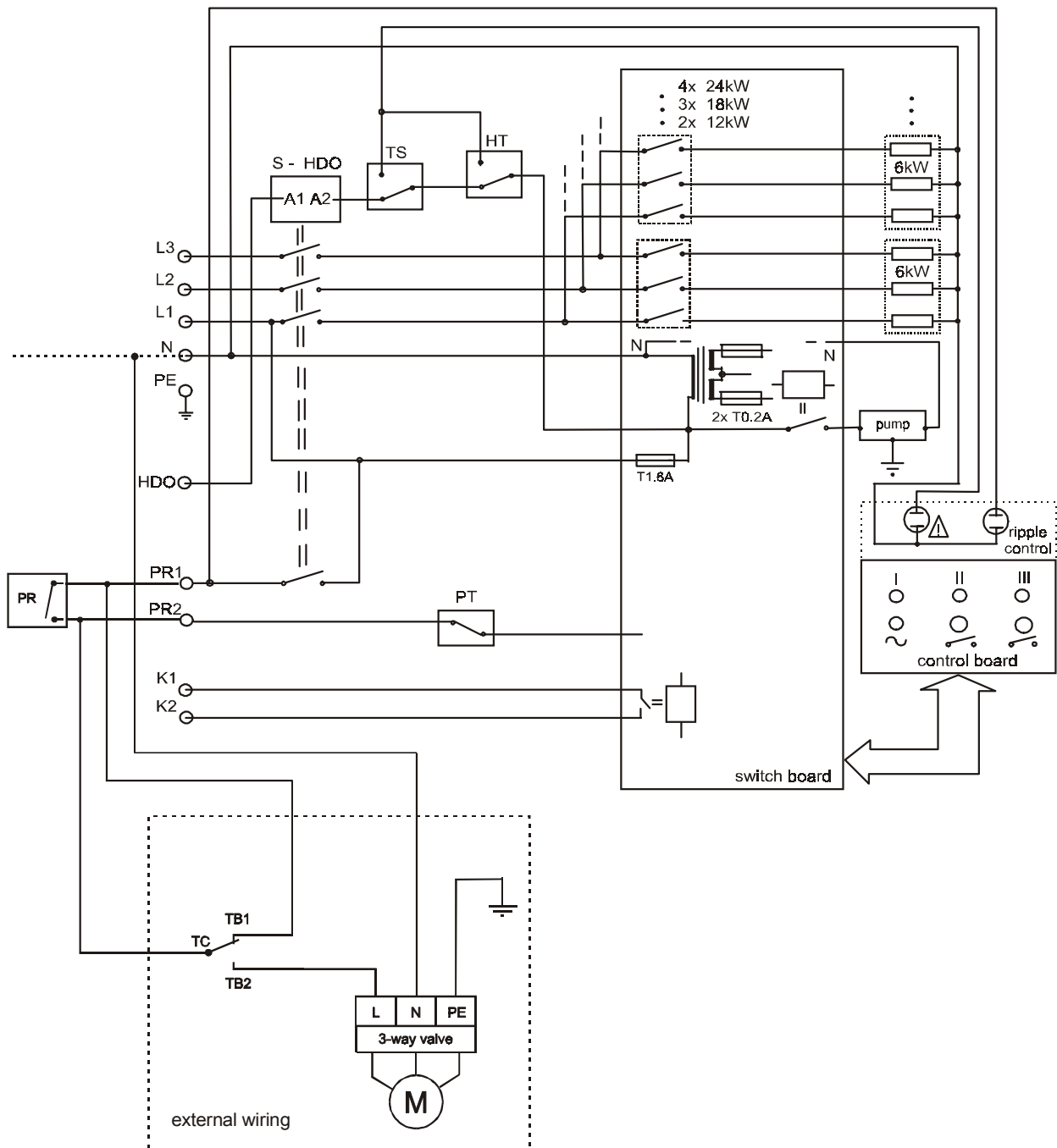

- TS – pressure switch 0,8 Bar
- HT – the emergency thermostat 100°C
- PT – the operating thermostat max. 85°C
- PR1, PR2 – the room thermostat 230 V / 0,1 A
- HDO – ripple control (RC)
- S-HDO – RC contactor
- K1, K2 – cascade (only 21 kW and 24 kW)
- R – switching relay
- TC, TB1, TB2 – thermostat contacts of DHW tank